

Fluid metering

METERING PUMP

FOR METERING AND BULK FLUID TRANSFER

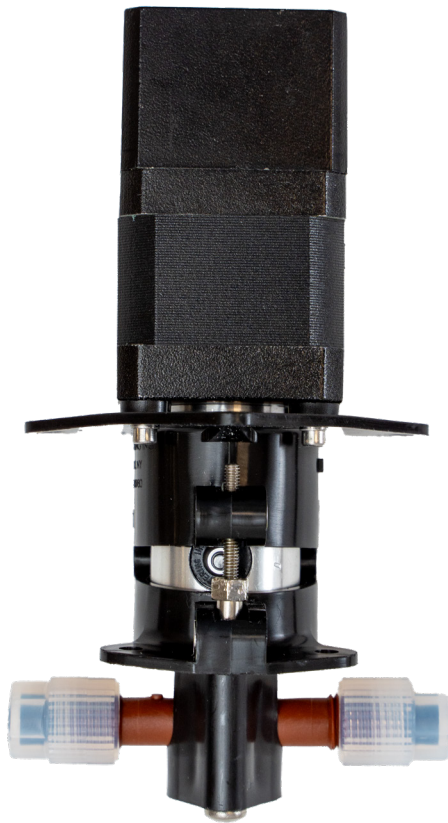

Fluid Metering's innovative valveless pump engineered for optimal bulk fluid transferring with exceptional accuracy. This pump manages a broad spectrum of flow rates and fluid types, including highly viscous solutions.

The pump's CeramPump® technology utilizes a unique rotating ceramic piston, eliminating common valve issues. Designed to withstand the challenges posed by waste solids that typically compromise valves, this pump maintains 0.5% precision for millions of cycles without maintenance or recalibration. Its compact size easily integrates into new and existing systems requiring a 24V DC power supply, making it versatile for diverse OEM life science applications.

FEATURES & BENEFITS

- CeramPump® valveless technology simplifies fluidic architecture with one moving part in fluid path
- Internal sapphire-hard ceramics are chemically inert, dimensionally stable, and abrasion resistant
- Small compact design
- Configurable options available
- Brushless DC motor 24V
- Self-priming
- Ideal for high flow metering applications
- Maintains 0.5% precision for millions of cycles without maintenance or recalibration

REV-B



Fluid Metering's facility is certified to the ISO 9001:2015 international standard. Product components are manufactured to meet EU RoHS and REACH compliance requirements.

Fluid metering

METERING PUMP

FOR METERING AND BULK FLUID TRANSFER

PUMP SPECIFICATIONS

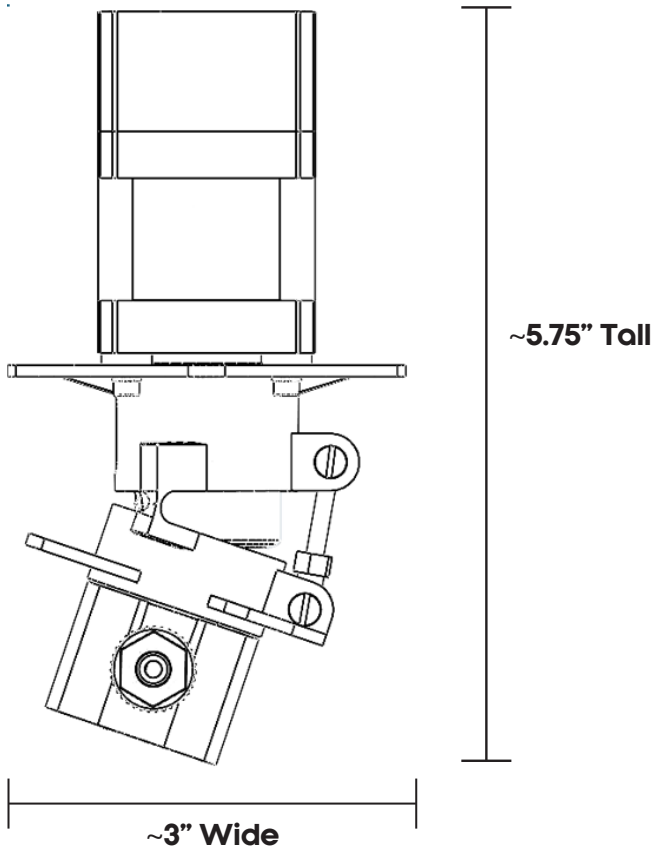

WETTED MATERIAL OPTIONS:

Ceramic: Alumina, Zirconia
Pump Housing: PVDF, ETFE, Polypropylene

SEAL MATERIAL OPTIONS:

PTFE, FKM, FFKM, Rulon AR, UHMW-PE

PORT OPTIONS:

1/4-28 UNF Threaded Ports,
Barb Fittings (1/8" - 1/4" Tubing ID),
1/4" Compression Nuts

CALIBRATED FLOW RATE:

Pump can be calibrated 20-400mL/min \pm 5%

MOTOR/DRIVER SPECIFICATIONS

FIXED SPEED MOTORS

MOTOR SPEED: 2000 RPM

VOLTAGE: 24V

RATED CURRENT: 0.88A / 2.0A

MOTOR DIRECTION: Bidirectional,
Calibrated Clockwise

STALL TORQUE: 0.2 Nm

OPERATING TEMPERATURE: 20°C to 60°C

VARIABLE SPEED MOTORS

SPEED CONTROL: Potentiometer/voltage

SPEED RANGE: 0 - 1700 RPM

VOLTAGE: 24V

RATED CURRENT: 0.88A / 2.0A

MOTOR DIRECTION: Bidirectional,
Calibrated Clockwise

STALL TORQUE: 0.2 Nm

OPERATING TEMPERATURE: 20°C to 60°C

CUSTOMIZED FLUIDIC SOLUTIONS

Be it a small tweak to existing technology or a full development project, our pumps and dispensers can be customized to accommodate dispense volume, flow rate, temperature, pressure, materials, and more.

Contact Us Today!

Rapid prototyping available within 10 business days*

*Prototype requests are subject to availability of parts and materials. Fluid Metering will confirm availability within 2 business days and provide an estimated shipping date.