

Fluid metering

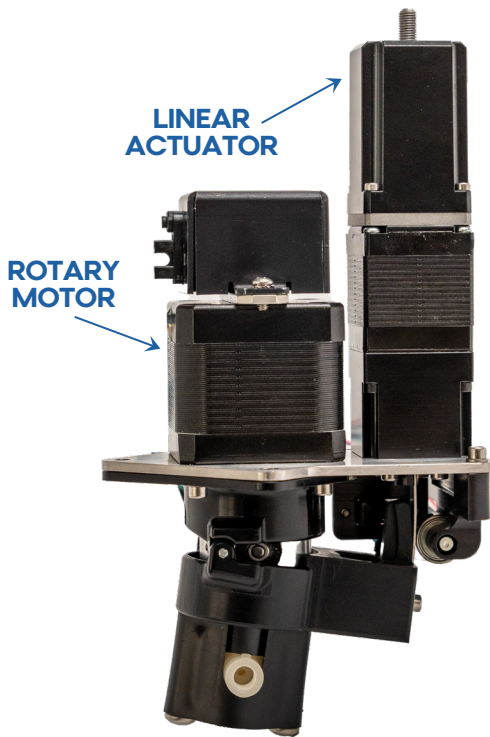

VARIABLE DISPENSE PUMP



Patent Pending

The **FENYX** Variable Dispense pump connects the needs of the life sciences field with an advanced miniaturized fluidic system designed to manipulate and control small volumes of fluid at the microscale level for a broad range of applications.

Achieving optimal performance in accuracy and repeatability with innovative design modifications, this product enables the ability to do precision microliter dispensing, high flow washing, and priming with one single pump.

This technologically advanced fluidic device not only meets the growing demand for simplified architecture, it also provides increased throughput, decreased cost of ownership, and precise dispenses critical in life science applications.

FEATURES & BENEFITS

- CeramPump® valveless technology simplifies fluidic architecture with one moving part in fluid path
- Internal sapphire-hard ceramics are chemically inert, dimensionally stable, and abrasion resistant
- Calibratable home dispense volume
- Linear anti-backlash mechanism
- Differential linear encoder
- Self-priming, dispensing, and flushing functions
- Sub-microliter non-contact dispensing
- Maintains 0.5% precision for millions of cycles without maintenance or recalibration
- Enables increased throughput compared to alternative technologies
- Reduces system total cost of ownership compared to alternative technologies

REV-F



Fluid Metering's facility is certified to the ISO 9001:2015 international standard. Product components are manufactured to meet EU RoHS and REACH compliance requirements.

Fluid metering



VARIABLE DISPENSE PUMP

PUMP SPECIFICATIONS

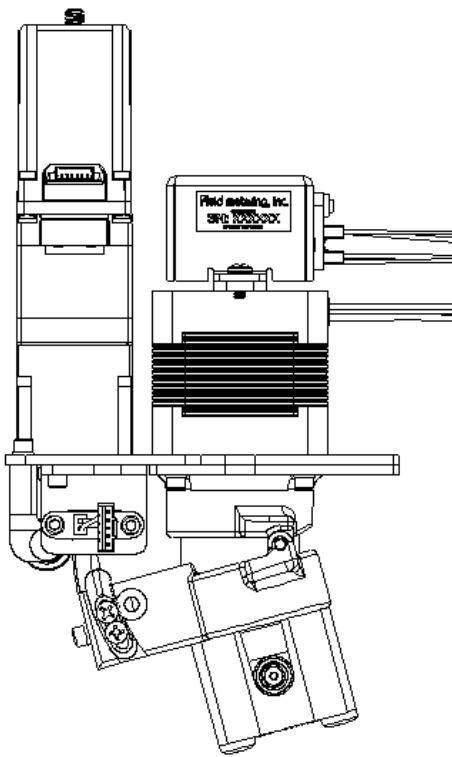

7.1" Tall

3.8" Wide

WETTED MATERIAL OPTIONS:

Ceramic: Alumina, Zirconia
Pump Housing: PVDF, ETFE, Polypropylene

SEAL MATERIAL OPTIONS:

Carbon-Filled PTFE, FKM, FFKM, Rulon AR

PORT OPTIONS:

1/4-28 UNF Threaded Ports,
Barb Fittings (1/8" - 1/4" Tubing ID),
1/4" Compression Nuts

DISPENSE VOLUME:

For 2 - 10 μ L

Accuracy of \pm 5%

Precision (CV) \leq 1%

For >10 - 200 μ L

Accuracy of \pm 1%

Precision (CV) \leq 0.5%

DRIVE MOTOR SPECIFICATIONS

RATED CURRENT:

Rotational: 2.0A

Linear: 1.0A

MOTOR FRAME:

Rotational: NEMA 17 (43mm)

Linear: NEMA 11 (28mm)

STEP ANGLE:

Rotational & Linear:

1.8° Full Step

MOTOR SPEED:

Rotational: Up to 1000 RPM

Linear: Up to 1900 RPM

MOTOR DIRECTION:

Rotational: Clockwise

Linear: Clockwise &

Counterclockwise

OPERATING TEMPERATURE:

0°C to 50°C

FENYX	Dispense Volume (μ L/rev)		Flow Rate (mL/min)	
	min	max	1 RPM	1000 RPM
FENYX-100	0.75	110	0.00075	110
FENYX-200	2	200	0.002	200
FENYX-400	4	400	0.004	400

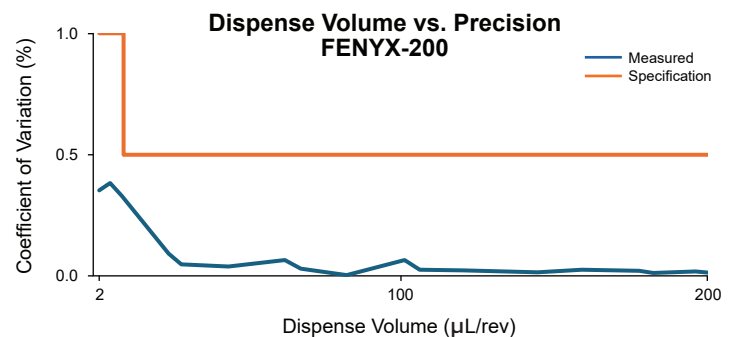

- Maximum standard operating pressure: 30 PSIG

CUSTOMIZED FLUIDIC SOLUTIONS

Be it a small tweak to existing technology or a full development project, our pumps and dispensers can be customized to accommodate dispense volume, flow rate, temperature, pressure, materials, and more.

Contact Us Today!

Rapid prototyping available within 10 business days*

*Prototype requests are subject to availability of parts and materials. Fluid Metering will confirm availability within 2 business days and provide an estimated shipping date.